

## YZR YZ 系列冶金及起重用三相异步电动机

YZR、YZ Series Induction Motors For Cranes And Metallurgical Applications



机座号 YZ112~250  
YZR112~400

功率 1.5~30kW  
1.5~200kW

基准工作制 S3

负载持续率 (FC) 40%

一般环境用 (40°C)

F 级绝缘 IP44

冶金环境用 (60°C)

H 级绝缘 IP54

**适用于:** 冶金和矿山行业中驱动各种型式的起重机械及其它类似设备, 特别适用于短时或断续周期性运转, 频繁启动、制动, 有时过负载及有显著振动与冲击的设备。

**Applications:** All metallurgy and lifting machines or the similar equipment. It is suitable for driving the short time on duty or continuous on duty equipment that frequent starting, braking and significant vibration and impacting is existed. Basic Duty Type is S3 at 40% Load Duration.

**特点:** 具有较大的过载能力和较高的机械强度, YZR 系列为绕线转子电动机, YZ 系列为鼠笼转子电动机。

**Features:** Processes the ability of overload and mechanic strength. The type of YZR series rotor is winding rotor, but YZ series is squirrel-cage rotor.

### 性能数据 Performance Data

### YZ

型号	工作制	S2																		S3																		转动惯量 (kg.m <sup>2</sup> )						
		30 分钟						60 分钟						15%						25%						40%						60%							100%					
		项目	kW	I <sub>1</sub> A	n r/min	kW	I <sub>1</sub> A	n r/min	kW	I <sub>1</sub> A	n r/min	kW	I <sub>1</sub> A	n r/min	kW	I <sub>1</sub> A	n r/min	kW	I <sub>1</sub> A	n r/min	T <sub>m</sub>	T <sub>st</sub>	lst A	kW	I <sub>1</sub> A	n r/min	kW	I <sub>1</sub> A	n r/min															
同步转速 1000r/min																																												
YZ112M	1.8	4.9	892	1.5	4.3	920	2.2	6.5	810	1.8	4.9	892	1.5	4.3	920	2	2	20	1.1	2.7	946	0.8	3.5	980	0.022																			
YZ132M1	2.5	6.5	920	2.2	5.9	935	3	7.5	804	2.5	6.5	920	2.2	5.9	935	2	2	27	1.8	5.3	950	1.5	4.9	960	0.056																			
YZ132M2	4	9.2	915	3.7	8.8	912	5	12	890	4	9.2	915	3.7	8.8	912	2	2	42	3	7.5	940	2.5	7.2	945	0.062																			
YZ160M1	6.3	14	922	5.5	13	933	7.5	17	903	6.3	14	922	5.5	13	933	2	2	60	5	12	940	4	10	953	0.114																			
YZ160M2	8.5	18	943	7.5	16	948	11	25	926	8.5	18	943	7.5	16	948	2.3	2.3	92	6.3	14	956	5.5	13	961	0.143																			
YZ160L	13	29	936	11	25	953	15	32	920	13	29	936	11	25	953	2.5	2.5	140	9	21	964	7.5	19	972	0.192																			
同步转速 750r/min																																												
YZ160L	9	21	694	7.5	18	705	11	27	675	9	21	694	7.5	18	705	2.3	2.3	98	6	16	717	5	14	724	0.192																			
YZ180L	13	30	675	11	26	694	15	35	654	13	30	675	11	26	694	2.5	2.5	130	9	22	710	7.5	19	718	0.352																			
YZ200L	19	40	697	15	33	710	22	48	686	19	40	697	15	33	710	2.5	2.5	182	13	28	714	11	26	720	0.622																			
YZ225M	26	54	701	22	46	712	33	69	687	26	54	701	22	46	712	2.5	2.5	275	19	40	718	17	38	720	0.82																			
YZ250M1	35	74	681	30	63	694	42	89	663	35	74	681	30	63	694	2.5	2.5	350	26	56	702	22	45	717	1.432																			





## 性能数据 Performance Data

## YZR

型 号	工 作 制 FC	S2												S3																							
		30 分钟 min				60 分钟 min				15%				25%				40%						60%				100%									
		项目	kW	I1	I2	n	kW	I1	I2	n	kW	I1	I2	n	kW	I1	I2	n	kW	I1	I2	Tm	I0	n	η	cosφ	kW	I1	I2	n	kW	I1	I2	n			
同步转速 1000 r/min																																					
YZR112M	1.8	5.3	13.4	815	1.5	4.6	12.5	866	2.2	6.6	18.4	725	1.8	5.3	13.4	815	1.5	4.6	12.5	2.3	3.37	866	65	0.77	1.1	3.8	7.32	912	0.8	3.5	5.16	940					
YZR132M1	2.5	6.5	12.9	892	2.2	6.1	12.6	908	3	8	16.1	855	2.5	6.5	12.9	892	2.2	6	12.6	2.3	4.04	908	70	0.77	1.8	5.4	8.96	921	1.5	5	7.3	940					
YZR132M2	4	9.7	14.2	900	3.7	9.2	14.5	908	5	12.3	18.2	875	4	9.7	14.2	900	3.7	9.2	14.5	2.3	8.58	908	75.5	0.78	3	7.9	10.2	937	2.5	7.5	8.4	950					
YZR160M1	6.3	16.4	29.4	921	5.5	15	25.7	930	7.5	18.5	35.4	910	6.3	16.4	29.4	921	5.5	15	25.7	2.3	7.95	930	75.5	0.78	5	14	22.9	935	4	12.5	18.2	944					
YZR160M2	8.5	19.6	29.8	930	7.5	18	26.5	940	11	24.6	39.6	908	8.5	19.6	29.8	930	7.5	18	26.5	2.5	11.2	940	79	0.8	6.3	16	21.7	949	5.5	15	18.8	956					
YZR160L	13	28.6	31.6	942	11	24.5	27.6	957	15	34.7	39	920	13	28.6	31.6	912	11	25	27.6	2.5	13	945	82	0.8	9	21	22.3	952	7.5	18.8	18.5	970					
YZR180L	17	36.7	49.8	955	15	33.8	46.5	962	20	42.6	58.7	946	17	36.7	49.8	955	15	33.8	46.5	2.8	18.8	962	84	0.81	13	29.7	37.3	968	11	25.5	31.5	975					
YZR200L	26	56.1	82.4	956	22	49	69.9	964	33	62	103	942	26	56	82.4	956	22	49	70	2.8	26.6	964	86	0.8	19	44.5	60.5	969	17	40.5	52.6	973					
YZR225M	34	70	85	957	30	62	74.4	962	40	80	101	917	34	70	85	957	30	62	74.4	2.8	29.9	962	88	0.82	26	55	64.5	968	22	50	54.2	975					
YZR250M1	42	80	103	960	37	70.5	91.5	965	50	99	123	950	42	80	103	960	37	70.5	91.5	2.8	26.5	960	89	0.89	32	61	79	970	28	55	69	975					
YZR250M2	52	97	110	958	45	84.5	95	965	63	121	134	947	52	97	110	958	45	84.5	95	2.8	28.2	965	90.5	0.89	39	73	83	969	33	64	71	974					
YZR280S	63	118	142	966	55	102	129.8	969	75	144	170	960	63	118	142	966	55	102	120	2.8	34	969	91	0.9	48	88	107	972	40	76	89	976					
YZR280M	85	157	140	966	75	139	124	970	100	185	166	960	85	157	140	966	75	139	124	2.8	47.5	970	91.8	0.89	63	118	104	975	50	96.3	82	980					
同步转速 750r/min																																					
YZR160L	9	22.4	28.1	694	7.5	19.1	23	705	11	27.5	35.5	676	9	22.4	28.1	694	7.5	19.1	23	2.5	12.7	705	78.5	0.72	6	16.4	18.2	712	5	14	15	724					
YZR180L	13	29.1	47.8	700	11	27	44	700	15	34	56	690	13	29.1	47.8	700	11	27	44	2.5	14.8	700	81	0.77	9	21.9	32.1	720	7.5	19.6	26.6	726					
YZR200L	18.5	40	67.2	701	15	33.5	53.5	712	22	48	81	690	18.5	40	67.2	701	15	33.5	53.5	2.8	17.8	712	85	0.78	13	30	46	718	11	27	38.7	723					
YZR225M	26	55	71.2	708	22	46.9	59.1	715	33	70	92	696	26	55	71.2	708	22	46.9	59.1	2.8	24.2	715	86	0.79	18.5	41	49.5	721	17	38	45	723					
YZR250M1	35	64	80	715	30	63.4	67.7	720	42	75	97.5	710	35	64	80	715	30	63.4	68.8	2.8	31.4	720	87	0.8	26	52	59	725	22	46	49.7	729					
YZR250M2	42	86	79	716	37	78	70	720	52	103	98	706	42	86	79	716	37	78	70	2.8	36.9	720	88	0.82	32	68	60	725	27	60	51	729					
YZR280S	52	108	106	712	45	96.5	92	717	63	129	130	704	52	108	106	712	45	96.5	92	2.8	48	717	88.8	0.8	39	86	79.4	722	33	76.3	67	726					
YZR280M	63	126	110	722	55	111	92.5	725	75	150	132	715	63	126	110	722	55	111	92.5	2.8	52.3	725	89	0.84	48	103	82.8	730	40	93	68.7	732					
YZR315S	85	165	178	722	75	147	157	725	100	200	162	715	85	165	178	722	75	146	157	2.8	62	725	89	0.85	63	126	131	729	55	105	104	731					
YZR315M	100	190	184	715	90	172	161	720	125	250	232	717	100	190	184	715	90	172	161	2.8	57.7	720	90	0.87	75	140	136	725	63	124	114	728					
同步转速 600r/min																																					
YZR280S	42	92	177	571	37	84.8	153	560	55	112	235	564	42	92	177	571	37	84.8	153	2.8	44.2	572	86	0.76	32	77	133	578	27	69	112	582					
YZR280M	55	127	207	556	45	104	165	560	63	146	241	548	55	127	207	556	45	104	165	2.8	63.6	560	86	0.77	37	90	136	569	33	89.6	118	587					
YZR315S	63	132	162	580	55	118	139	580	75	154	194	574	63	133	162	580	55	118	139	2.8	62.5	580	88.5	0.79	48	107	122	585	40	95.2	101	588					
YZR315M	85	179	171	576	75	160	149	579	100	210	203	570	85	179	171	576	75	160	149	2.8	85.3	579	89	0.79	63	140	125	584	50	125	98.5	587					
YZR355M	110	218	207	581	90	180	167	585	132	266	252	576	110	218	207	581	90	180	167	2.8	83	589	90	0.81	75	154	140	588	63	136	117	589					
YZR355L1	132	257	213	576	110	217	172	582	160	314	261	571	132	257	213	587	110	217	172	2.8	90	582	91	0.82	90	181	143	585	75	157	119	588					
YZR355L2	150	293	194	588	132	262	168	588	185	353	241	585	150	293	194	588	132	262	168	2.8	126	588	92	0.82	110	226	142	591	90	191	116	592					
YZR400L1	190	390	290	585	160	338	244	587	220	445	336	581	190	390	290	584	160	338	244	2.8	175	587	91.5	0.79	135	294	206	592	115	268	174	591					
YZR400L2	240	490	302	585	200	427	252	588	270	540	340	582	240	490	302	586	200	423	252	2.8	213	588	92.2	0.77	170	372	214	591	145	332	183	592					



## 性能数据 Performance Data

## YZR

型 号	工 作 制 FC	S4、S5																							
		150 次/小时 150 starts/h												300 次/小时 300 starts/h						600 次/小时 600starts/h					
		25%				40%				60%				40%			60%			60%					
		项目	kW	I1	I2	n	kW	I1	I2	n	kW	I1	I2	n	kW	I1	I2	n	kW	I1	I2	n	kW	I1	I2
同步转速 1000r/min																									
YZR112M	1.6	4.75	11.3	845	1.3	4.2	8.85	890	1	3.75	6.57	920	1.2	4	8	900	0.9	3.7	5.87	930	0.7	3.4	4.46	946	
YZR132M	2.2	6	11.2	908	2	5.7	10	913	1.7	5.3	8.4	931	1.8	5.4	9	926	1.6	5.1	7.87	936	1.35	4.9	6.8	946	
YZR132M	3.7	9.7	13.1	915	3.5	9.2	11.2	925	2.8	8.5	9.65	940	3.3	9.4	11.9	925	2.7	8.5	9.65	940	2.3	6	7.5	950	
YZR160M	5.8	15.5	27.3	927	5	14.1	23.4	935	4.8	13.5	22.7	937	4.8	14.1	23.4	935	4.5	13.8	22.4	937	3.8	12.2	17.5	946	
YZR160M	7.5	18	27.6	940	7	17.1	25.6	945	6	15.6	21.8	954	6	15.6	21.8	954	5.5	14.8	19.8	959	4	13	14.2	970	
YZR160L	11	28.3	27.8	950	10	23	25	957	8	19.5	19.8	969	9	19.5	19.8	969	7.5	18.7	18.5	971	6	16.7	14.2	978	
YZR180L	15	33	43.7	960	13	29.5	37.7	965	12	28	34.6	969	12	28	34.6	969	11	26.6	31.7	972	9	23.6	22.9	978	
YZR200L	21	47	55.4	965	18.5	42.5	48.5	970	17	40.5	53.8	973	17	40.5	52.6	973	15	37	40	975	11	31.5	28.5	981	
YZR225M	28	58	70	965	25	53	62.2	969	22	50	54.5	973	22	50	54.5	973	20	46	49.4	977	15	39	36.8	982	
YZR250M	33	63	82.6	970	30	58	74.9	973	28	54	69.8	975	26	52	64.6	977	25	50	62.1	978	17.5	39	43.2	984	
YZR250M	42	78	90.5	967	37	70	79.3	971	33	63	70.5	975	31	60	66.1	976	30	58	63.9	977	24	49	50.9	981	
YZR280S	52	95	116	970	45	83	100	974	42	80	93.6	975	40	76	89	977	37	71	82.2	978	30	64	66.5	980	
YZR280M	70	130	115	972	62	114	102	975	55	91	104	978	52	98	85.5	979	47	92	77.3	981	37	78	61	982	
同步转速 750r/min																									
YZR160L	7.5	19	22.8	712	7	18.1	21.2	716	5.8	16.4	17.3	724	6	16.7	18	722	5	15.5	14.9	727	3.8	13.7	11.2	732	
YZR180L	11	25.4	40.6	711	10	23.5	36.6	717	8	20.5	28.8	728	8	20.5	28.8	728	7.5	19.7	26.9	729	5.8	17.8	20.6	736	
YZR200L	15	34	54.1	713	13	30	46.6	718	12	28.2	43	720	12	28.2	43	720	11	27	39	724	9	23	28.1	731	
YZR225M	21	45	56.8	718	18.5	41	49.7	721	17	38	45.6	724	17	38	45.6	724	15	35	40	727	11	31	29.1	733	
ZR250M1	29	61.5	68.5	700	25	54	58.7	705	22	49	51.9	712	22	49	51.9	712	20	46	46.2	716	15	39	34.2	725	
YZR250M	33	70	62.5	725	30	64	56.6	727	28	61	52.8	728	26	58	48.9	730	25	57	47	731	18.5	45	34.4	736	
YZR280S	42	91	85.8	719	37	83	75.6	723	33	76.3	67	726	31	74	63.5	728	30	72	61.5	732	24	64	49	733	
YZR280M	52	104	90.2	727	45	93	77.7	730	42	89	72.4	732	42	89	72.4	732	37	83	63.5	735	30	73	51.4	737	
YZR315S	64	118	132.7	731	60	110.5	124.2	733	56	106	115.8	733	52	100	107	735	48	94	98.8	736	35	80	71.7	740	
YZR315M	75	142	136	725	72	136	130.7	725	65	126	117.6	727	60	120	108	729	55	116	99	729	41	100	73.7	732	
同步转速 600 r/min																									
YZR280S	33	78.7	141.8	578	30	74	125	579	28	71	116	580	26	68	108	582	25	66	103	583	17	56	69.8	588	
YZR280M	42	98.7	154	565	37	90	136	569	33	84.3	118	573	31	82	110	574	28	78.5	98	577	22	72.5	75	582	
YZR315S	50	110	128.4	583	45	100	115.3	585	42	96	107.4	586	40	94	102.2	587	37	90	94.5	587	30	84	76.3	589	
YZR315M	65	144	129	584	63	136	119	585	55	130	109	586	53	126	98.7	587	48	124	94.7	588	37	114	73	589	
YZR355M	80	160.5	149.7	587	72	156	134.5	588	65	140	121	589	60	130	112	590	55	124	102.4	590	41	104	76.19	591	
YZR355L1	100	185	157	586	90	170	142	588	80	155	126.5	589	75	150	119	590	70	145	111	591	50	120	78.4	594	
YZR355L2	120	250	149.8	588	110	230	137.5	589	95	210	122.7	591	90	205	116.2	591	80	190	130.2	592	60	165	77.1	594	
YZR400L1	146	314	223	588	130	288	199	589	115	268	175	590	110	260	168	591	97	247	148	592	75	220	114	594	
YZR400L2	185	396	223	590	165	365	262	589	145	332	183	592	140	324	176	592	123	298	155	592	95	265	122	594	

## 外形及安装尺寸 Dimensions

mm

 IM1001、IM1002 及 IM1003、IM1004 机座带底脚、端盖上无凸缘的 YZ 系列电机  
 Frame with feet and endshield without flange (IM1001,IM1002,IM1003,IM1004)

YZ

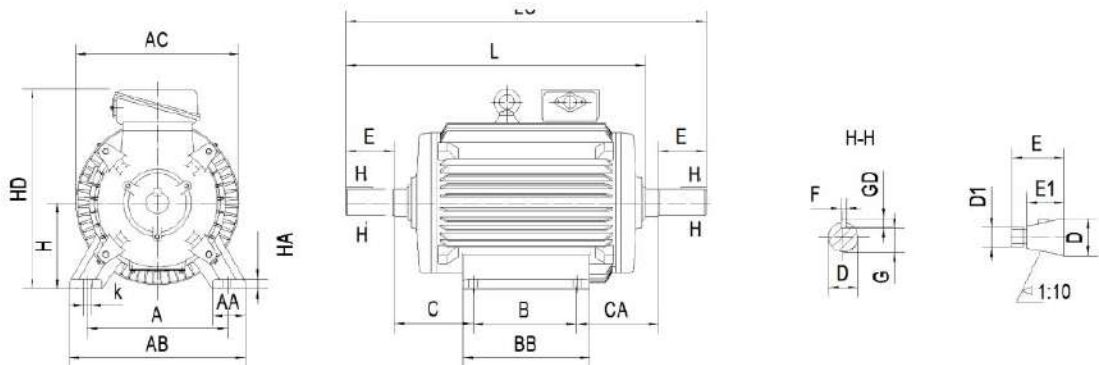

机座号 Frame	安装尺寸 Mounting Dimension														外形尺寸 Overall Dimension							
	机座 Frame							轴端 Shaft End							AA	AB	AC	BB	HA	HD	L	LC
	A	B	C	CA	H	K	螺栓直径	D	D1	E	E1	G	GD	F								
112M	190	140	70	135	112	12	M10	32	—	80	—	27	8	10	50	250	245	235	18	335	420	505
132M	216	178	89	150	132	12	M10	38	—	80	—	33	8	10	50	275	285	260	20	365	495	577
160M	254	210	108	180	160	15	M12	48	—	110	—	42.5	9	14	60	320	325	290	25	425	608	718
160L	254	254	108	180	160	15	M12	48	—	110	—	42.5	9	14	60	320	325	335	25	425	650	762
180L	279	279	121	180	180	15	M12	55	M36×3	110	82	19.9	9	14	70	360	360	380	25	465	685	800
200L	318	305	133	210	200	19	M16	60	M42×3	140	105	21.4	10	16	85	405	405	400	28	510	780	928
225M	356	311	149	258	225	19	M16	65	M42×3	140	105	23.9	10	16	85	455	430	410	28	545	850	998
250M	406	349	168	295	250	24	M20	70	M48×3	140	105	25.4	11	18	95	515	480	510	30	605	935	1092

IM3001 及 IM3003 卧式安装、机座不带底脚、端盖有凸缘的 YZ 系列电机

Frame without feet and endshield with flange horizontal mounting motor (IM3001, IM3003)

YZ

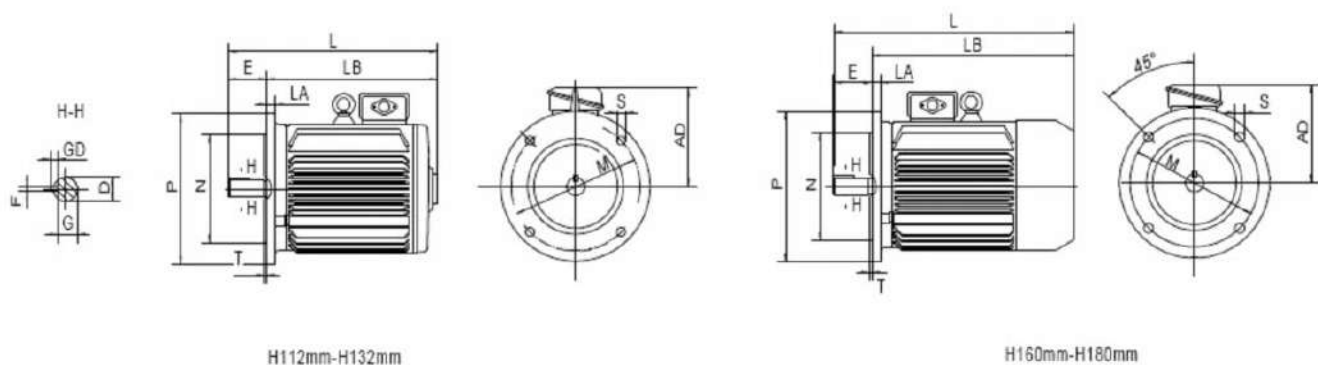

H112mm-H132mm

H160mm-H180mm



机座号 Frame	安 装 尺 寸 Mounting Dimension																外形尺寸 Overall Dimension		
	凸 缘 端 Flange									轴 端 Shaft End									
	凸缘号	M	N	P	LA	T	S	螺栓直径	孔数(个)	D	D1	E	E1	F	GD	G	AD	L	LB
112M	FF215	215	180	250	14	4	15	M12	4	32	-	80	-	10	8	27	220	430	350
132M	FF265	265	230	300	14	4	15	M12	4	38	-	80	-	10	8	33	230	495	415
160M	FF300	300	250	350	18	5	19	M16	4	48	-	110	-	14	9	42.5	260	700	590
160L	FF300	300	250	350	18	5	19	M16	4	48	-	110	-	14	9	42.5	260	743	633
180L	FF300	300	250	350	18	5	19	M16	4	55	M36×3	110	82	14	9	19.9	280	735	625

IM3011 及 IM3013 立式安装、机座不带底脚、端盖有凸缘、轴伸向下的 YZ 系列电机  
 Frame without feet, endshield with flange and shaft down mounting motor (IM3011, IM3013)

## YZ

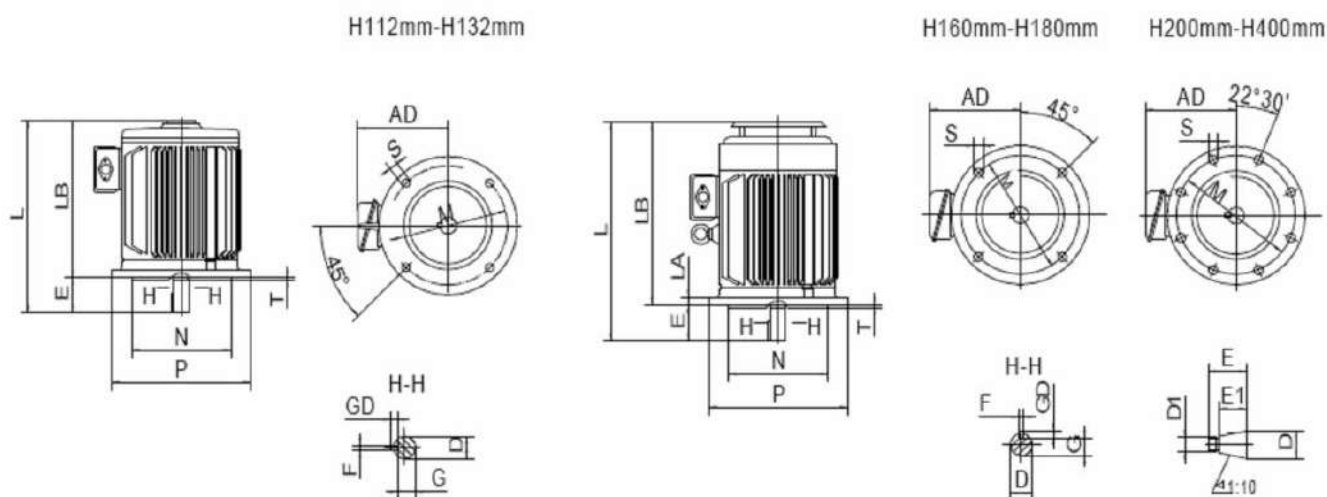

机座号 Frame	安 装 尺 寸 Mounting Dimension																外形尺寸 Overall Dimension		
	凸 缘 端 Flange									轴 端 Shaft End									
	凸缘号	M	N	P	LA	T	S	螺栓直径	孔数(个)	D	D1	E	E1	F	GD	G	AD	LB	L
112M	FF215	215	180	250	14	4	15	M12	4	32	-	80	-	10	8	27	220	350	430
132M	FF265	265	230	300	14	4	15	M12	4	38	-	80	-	10	8	33	230	415	495
160M	FF300	300	250	350	18	5	19	M16	4	48	-	110	-	14	9	42.5	260	590	700
160L	FF300	300	250	350	18	5	19	M16	4	48	-	110	-	14	9	42.5	260	633	743
180L	FF300	300	250	350	18	5	19	M16	4	55	M36×3	110	82	14	9	19.9	280	625	735
200L	FF400	400	350	450	20	5	19	M16	8	60	M42×3	140	105	16	10	21.4	320	715	855
225M	FF400	400	350	450	20	5	19	M16	8	65	M42×3	140	105	16	10	23.9	320	775	915
250M	FF500	500	450	550	22	5	19	M16	8	70	M48×3	140	105	18	11	25.4	355	865	1005

IM1001、IM1003 及 IM1002、IM1004、机座带底脚、端盖无凸缘的 YZR 系列电机  
 Frame with feet and endshield without flange (IM1001,IM1002,IM1003,IM1004)

## YZR

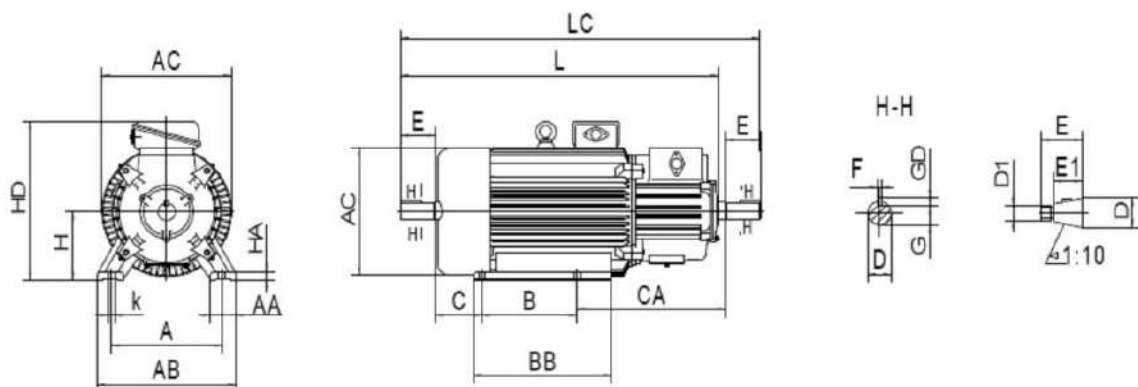

机座号 Frame	安 装 尺 寸 Mounting Dimension														外 形 尺 寸 Overall Dimension							
	机 座 Frame							轴 端 Shaft End														
	A	B	C	CA	H	K	螺栓 直径	D	D1	E	E1	G	GD	F	AA	AB	AC	BB	HA	HD	L	LC
112M	190	140	70	300	112	12	M10	32	—	80	—	27	8	10	50	250	245	235	18	335	590	670
132M	216	178	89	300	132	12	M10	38	—	80	—	33	8	10	50	275	285	260	20	365	645	727
160M	254	210	108	330	160	15	M12	48	—	110	—	42.5	9	14	60	320	325	290	25	425	758	868
160L	254	254	108	330	160	15	M12	48	—	110	—	42.5	9	14	60	320	325	335	25	425	800	912
180L	279	279	121	360	180	15	M12	55	M36×3	110	82	19.9	9	14	70	360	360	380	25	465	870	980
200L	318	305	133	400	200	19	M16	60	M42×3	140	105	21.4	10	16	85	405	405	400	28	510	975	1118
225M	356	311	149	450	225	19	M16	65	M42×3	140	105	23.9	10	16	85	455	430	410	28	545	1050	1190
250M	406	349	168	540	250	24	M20	70	M48×3	140	105	25.4	11	18	95	515	480	510	30	605	1195	1337
280S	457	368	190	540	280	24	M20	85	M56×4	170	130	31.7	12	20	100	575	535	530	32	665	1265	1438
280M	457	419	190	540	280	24	M20	85	M56×4	170	130	31.7	12	20	100	575	535	580	32	665	1315	1489
315S	508	406	216	600	315	28	M24	95	M64×4	170	130	35.2	12	22	110	640	620	580	35	750	1390	1562
315M	508	457	216	600	315	28	M24	95	M64×4	170	130	35.2	12	22	110	640	620	630	35	750	1440	1613
355M	610	560	254	630	355	28	M24	110	M80×4	210	165	41.9	12	25	120	740	710	730	38	840	1650	1864
355L	610	630	254	630	355	28	M24	110	M80×4	210	165	41.9	12	25	120	740	710	800	38	840	1720	1934
400L	686	710	280	630	400	35	M30	130	M100×4	250	200	50	12	28	136	855	840	910	45	950	1865	2120



IM3001 及 IM3003 卧式安装、机座不带底脚、端盖有凸缘的 YZR 系列电动机  
 Frame without feet and endshield with flange horizontal mounting motor (IM3001, IM3003)

### YZR

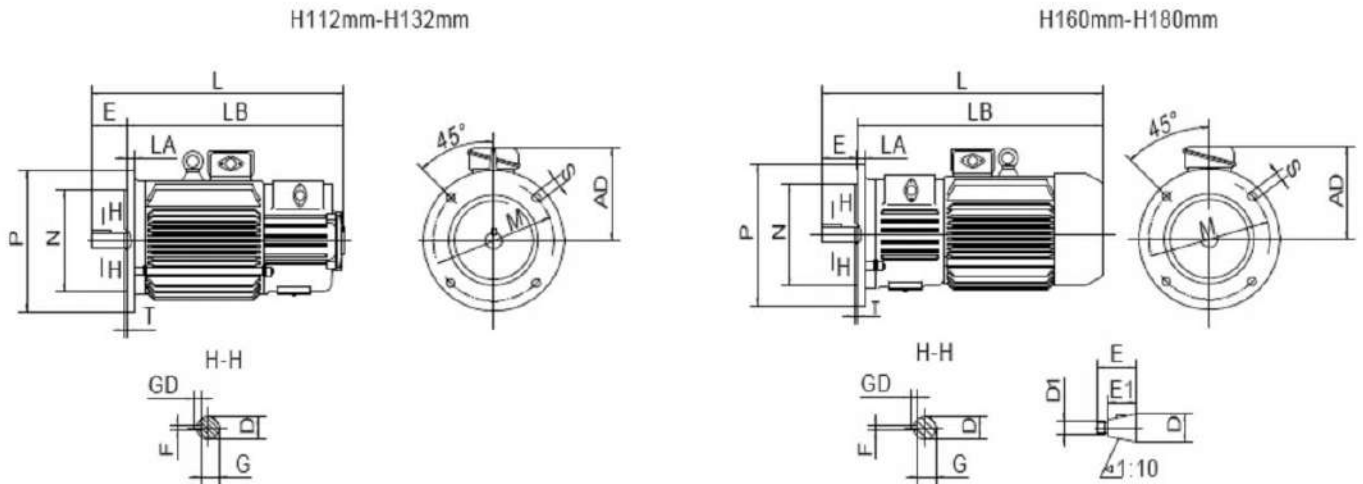

机座号 Frame	安装尺寸 Mounting Dimension																外形尺寸		
	凸缘端 Flange									轴端 Shaft End							Overall Dimension		
	凸缘号	M	N	P	LA	T	S	螺栓直径	孔数(个)	D	D1	E	E1	F	GD	G	AD	LB	L
112M	FF215	215	180	250	14	4	15	M12	4	32	—	80	—	10	8	27	220	515	595
132M	FF265	265	230	300	14	4	15	M12	4	38	—	80	—	10	8	33	230	565	645
160M	FF300	300	250	350	18	5	19	M16	4	48	—	110	—	14	9	42.5	260	718	828
160L	FF300	300	250	350	18	5	19	M16	4	48	—	110	—	14	9	42.5	260	762	872
180L	FF300	300	250	350	18	5	19	M16	4	55	M36×3	110	82	14	9	19.9	280	805	915

IM3011 及 IM3013 立式安装、机座不带底脚、端盖有凸缘、轴伸向下的 YZR 电动机  
 Frame without feet, endshield with flange and shaft down mounting motor (IM3011, IM3013)

### YZR

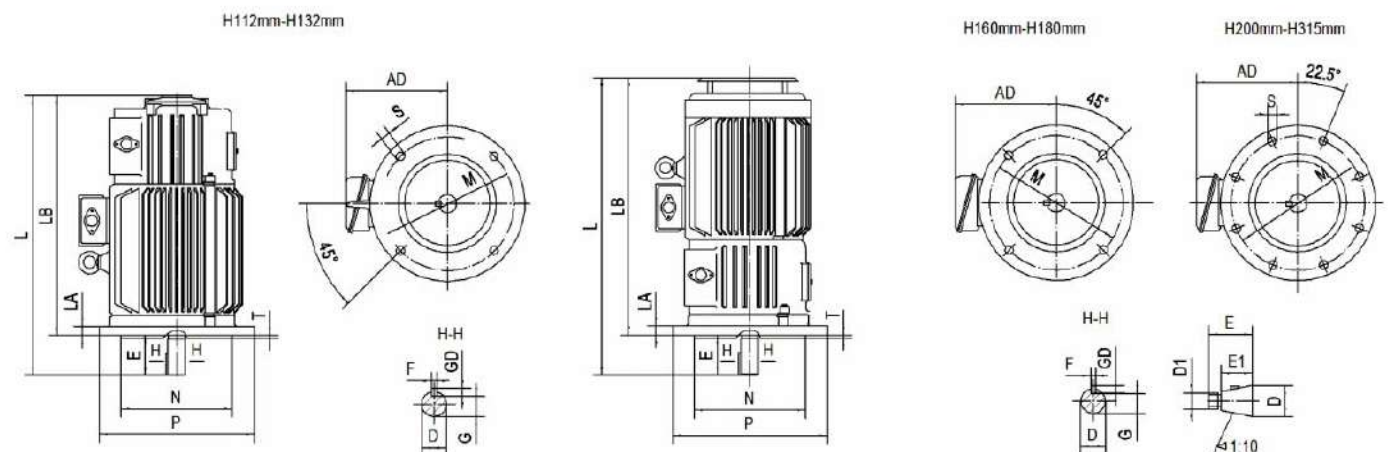

机座号 Frame	安 装 尺 寸 Mounting Dimension																外形尺寸 Overall Dimension		
	凸 缘 端 Flange									轴 端 Shaft End							AD	LB	L
	凸缘号	M	N	P	LA	T	S	螺栓直径	孔数(个)	D	D1	E	E1	F	GD	G			
112M	FF215	215	180	250	14	4	15	M12	4	32	—	80	—	10	8	27	220	515	595
132M	FF265	265	230	300	14	4	15	M12	4	38	—	80	—	10	8	33	230	565	645
160M	FF300	300	250	350	18	5	19	M16	4	48	—	110	—	14	9	42.5	260	718	828
160L	FF300	300	250	350	18	5	19	M16	4	48	—	110	—	14	9	42.5	260	762	872
180L	FF300	300	250	350	18	5	19	M16	4	55	M36×3	110	82	14	9	19.9	280	805	915
200L	FF400	400	350	450	20	5	19	M16	8	60	M42×3	140	105	16	10	21.4	320	910	1050
225M	FF400	400	350	450	20	5	19	M16	8	65	M42×3	140	105	16	10	23.9	320	970	1110
250M	FF500	500	450	550	22	5	19	M16	8	70	M48×3	140	105	18	11	25.4	355	1126	1266
280S	FF500	500	450	550	22	5	19	M16	8	85	M56×4	170	130	20	12	31.7	385	1200	1370
280M	FF500	500	450	550	22	5	19	M16	8	85	M56×4	170	130	20	12	31.7	385	1250	1420
315S	FF600	600	550	660	25	6	24	M20	8	95	M64×4	170	130	22	12	35.2	435	1305	1475
315M	FF600	600	550	660	25	6	24	M20	8	95	M64×4	170	130	22	12	35.2	435	1355	1525

### 常用的结构及安装型式，以及适用的机座号见下表

Conventional mounting type and suitable frame size are given in following table

安装型式 Mounting Type	代号 Symbol	制造范围 (机座号) Range (Frame Size)		备注 Note
		YZ 系列	YZR 系列	
	IM1001	112~160	112~160	单圆柱轴伸 Single Cylindrical Shaft End
	IM1003	180~250	180~400	单锥形轴伸 Single Conical Shaft End
	IM1002	112~160	112~160	双圆柱轴伸 Double Cylindrical Shaft End
	IM1004	180~250	180~400	双锥形轴伸 Double Conical Shaft End
	IM3001	112~160	112~160	单圆柱轴伸 Single Cylindrical Shaft End
	IM3003	180	180	单锥形轴伸 Single Conical Shaft End
	IM3011	112~160	112~160	单圆柱轴伸 Single Cylindrical Shaft End
	IM3013	180~250	180~315	单锥形轴伸 Single Conical Shaft End